

Bogue Oil, Inc.

5839 A Adderley Street
 Norfolk, VA 23502
 757-855-6251
www.bogueoil.com

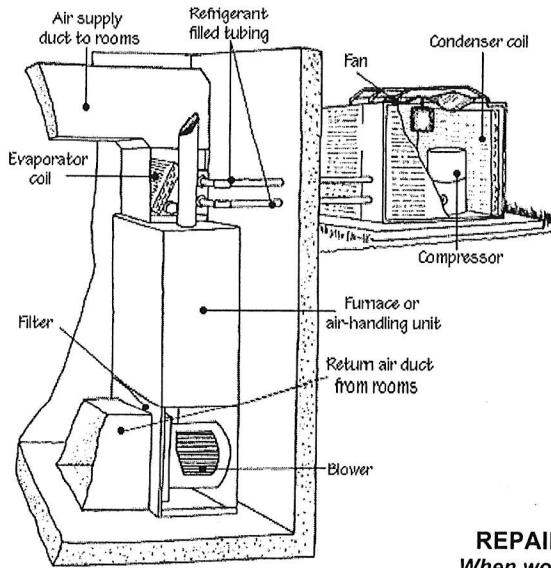

A/C Service Agreement

Inspection of A/C done at time of purchase of this agreement. Any part that does not pass initial inspection must be replaced or repaired at customers cost or it will not be covered under this contract at any later date.

REPAIR & REPLACEMENT PARTS
 When worn out due to normal cooling use

Adding or removing refrigerant is not covered under this plan.

PARTS COVERED

UP TO \$150 ALLOWANCE

CONDENSING UNIT INTERNAL WIRING
 CONTACTOR
 EXTERNAL CRANKCASE HEATER
 FUSES
 HARD START
 HIGH PRESSURE CONTROL
 HOLDING RELAY
 LOW PRESSURE CONTROL
 LOW VOLTAGE TRANSFORMER
 MOTOR PROTECTOR
 MOTOR STARTERS
 OUTDOOR DISCONNECT
 PRESSURE LIMIT & SAFETY CONTROLS

RELAYS
 RUNNING CAPACITORS
 TIME DELAY

BLOWER MOTOR
 CIRCUIT BOARDS
 CONDENSER FAN MOTOR
 CONDENSER FAN BLADES
 COMPRESSOR
 CONDENSATE PUMP & LINE

First & Last Name:	
Address, City, Zipcode	
Home #:	Work or Cell #:
Model Name:	Model # if available:
Serial # if Available:	
Initial Inspection Date:	Initial Inspector:

Annual Preventive Maintenance

- **Inspection, Cleaning, Adjustment**
 Inspection done to confirm your A/C is operating at peak performance and at its maximum efficiency
- **Lubrication**
 Designed to extend the life of the system and reduce the likelihood of expensive problems developing
- **Operational Check**
 Controls for proper functioning and efficiency

Preventive maintenance is usually done between the months of May through August, between the hours of 8 a.m. & 5 p.m., only one per year under this contract.

Signature _____ Date _____

TERMS OF CONTRACT

1. Customer must be on automatic delivery for duration of contract and purchase their fuel only from Bogue Oil.
2. This contract becomes effective only if the serviceman determines upon the initial inspection that the oil furnace is in acceptable condition. If furnace is found not to be in acceptable condition, customer may choose to have it brought up to acceptable condition by paying for service at our regular service rates for parts and labor.
3. If automatic delivery is cancelled by customer or by Bogue because of non-payment of deliveries this contract will be void and non-refundable or pro-rated.
4. Any other parts not specifically mentioned will not be covered.
5. Bogue Oil reserves the right to terminate this agreement if the purchaser permits any person other than an employee or authorized agent of Bogue Oil to render service or adjustments to the equipment.
6. Calls taken under the following conditions will be charged for at current price for labor and parts.
 - Calls caused as a result of service procured from another source.
 - Calls caused where the **owner or renter** has attempted their own repairs.
 - Calls caused by other than operational normal wear and tear.
 - Stored materials obstructing equipment area, Customer not home and did not provide access to furnace for pre-arranged service call.
 - Damage from restricted or clogged chimney, poor draft conditions.
7. This agreement does not cover any handling of asbestos
8. Any permits or fees that are required are the financial responsibility of the and are not covered by the contract.
9. Bogue Oil is not liable for failure to provide service or materials when such failure is due to strike, fire, flood, freezing, accident, unforeseen weather events i.e. frozen oil & water lines, power outages, power surges or problems caused by home generators, fuel tank failure, water or sediment in the line, inability to obtain materials, war, action of any governmental body, or any other cause beyond the Company's control.
10. This contract is transferable from one customer to another, I.E. (Seller-Buyer), providing customer remains on automatic service.
11. Not responsible for any damages to home or unit when home/unit is unoccupied - some restrictions apply.

BOGUE OIL WILL RESPOND WITHIN 24 HOURS FOR ANY SERVICE REQUEST